

Instructions:

Tile Setting Requirements

Tile must be set from the high point of the bond beam and bedded out level. Scrape the top of the tile to remove any debris that would cause the fiber-optic receiver to fit unevenly around the perimeter. **See Fig. A**

Setting the Form

Peel the paper from the double faced tape (one foot at a time) and stick the form to the tile. It is helpful to slide a 2 inch piece of the fiber-optic receiver along the top of the tile when setting the form to establish the correct elevation. *The tile must be clean and free of dust before setting the form.* **See Fig. B**

Bending Instructions: Detailed form bending instructions are included with the Tie Wire Side Kit.

Note: During cold weather it may be necessary to warm the tile with a heat gun just prior to sticking the form.

Placing the Fiber-Optic Receiver

Insert the fiber-optic receiver into the notch provided in the form, making sure it is pressed down tight to the tile. Be sure to butt the joints together, as this receiver will be visible in the finished product. **See Fig. C**

* Bond Breaker

Cover the top of the bond beam with 15 lb. felt to act as a “bond breaker,” allowing the concrete deck to expand and contract without disturbing the tile. **See Fig. D**

*** Structural Considerations:** If the installation is a coping pour, ***DO NOT*** apply a bond breaker as it is necessary to adhere the concrete to the pool wall.

Placing the Tie Wires

Drive the concrete nails (provided) into the bond beam 14 inches apart, 8 inches back from the tile. Be sure to leave the tops of the nails exposed to attach the tie wires. Push the tie wires through the form, level with the top of the fiber-optic receiver, applying pressure while wrapping securely around the nails. **See Fig. D**

Note: In addition to bracing the form, the tie wires also insure that the fiber-optic receiver stays securely in place.

Pouring

Be sure to tap or vibrate the form while pouring to help eliminate any rock pockets or “honeycomb”.

Stripping / Finishing

Once the concrete is strong enough to support its own weight, the forms can be removed. Remove the tie wires by twisting the “pig tail,” severing the wires below the surface of the concrete. **See Fig. E**

Note: Removing the forms one section at a time retains moisture in the surface, allowing adequate time to finish the concrete.

Patented

041113

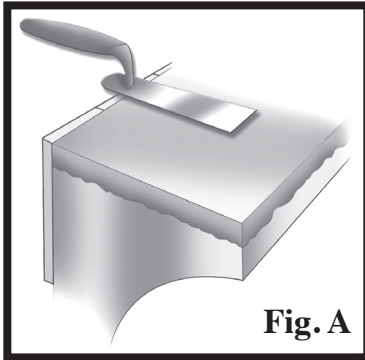

Fig. A

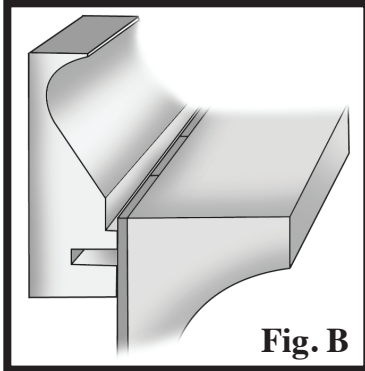

Fig. B

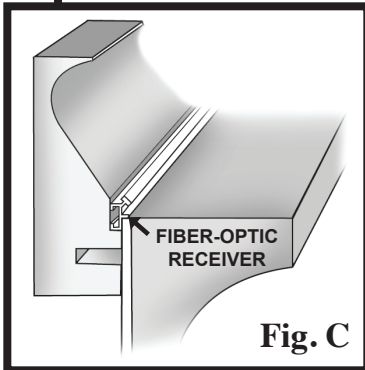

Fig. C

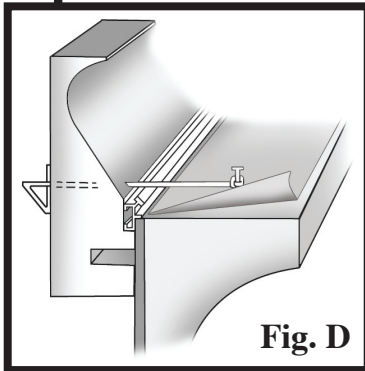

Fig. D

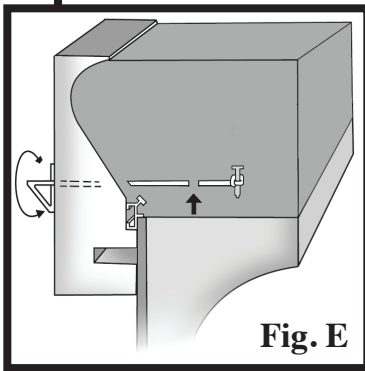

Fig. E